

LEDLine 60 DI

Suspended direct/Indirect pendant available in 2 lengths and body colour options, switchable power & selectable 5 CCT

- Offices
- Board rooms
- Showrooms
- Retail



Features

- Features 50° office LED as standard
- Branded LED's and driver system inside
- RAL9003 white as standard with black and grey options
- Available in 1.2m and 1.5m lengths

Options

- Integrated 3hr emergency -Standard (**M3**) - Self Testing Emergency (**STE**)
- DALI Monitor Emergency (**D3**)
- DALI (**DA**)
- Wall brackets (**WB**)
- Casambi wireless control (**BTC**)
- Suspension Kit (**SUS-2-2M**)
- Grey body – (**GR**)
- Black body – (**BK**)

Dimensions

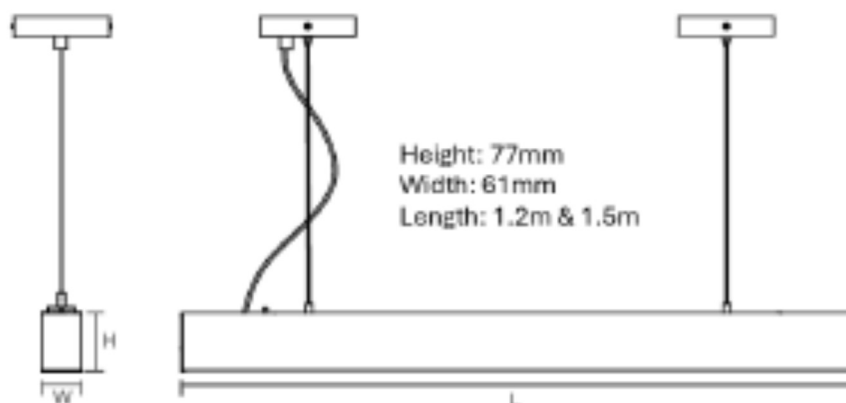

Product Code

LDL-4F-CCT-DI-WH LEDLine 30-50w, 5CCT 2700-5000K, 3600lm to 6000lm, 1200mm, white

LDL-5F-CCT-DI-WH LEDLine 30-50w, 5CCT 2700-5000K, 3600lm to 6000lm, 1500mm, white

** Suffix end of code (**M3**) for emergency facility or (**BTC**) for Casambi Wireless Control**

Example: LDL-4F-CCT-DI-WH-BTC LEDLine 60 1200mm 30-50w, 5CCT,white c/w Casambi