

Surface/Wall mounted die-cast aluminium base non-corrosive c/w opal polycarbonate diffuser & stainless-steel security fixings

- Car Park
- Boiler Room
- Bike Shed
- Industrial
- Workshop
- Laundry



## Features

- Die-cast aluminium base powder coat RAL9006
- Opal UV stabilised polycarbonate diffuser
- Wattage & 3CCT selectable
- Stainless Steel security fixing
- IK10 – BSEN 2262
- IP66

## Options

- Integrated 3hr emergency -Standard (M3) - Self Testing Emergency (STE)
- DALI Monitor Emergency (D3)
- DALI (DA)
- Batten mounted PIR Sensor (BPIR)
- Mirco-wave Sensor (MW1)
- Casambi wireless control (BTC)

## Dimensions

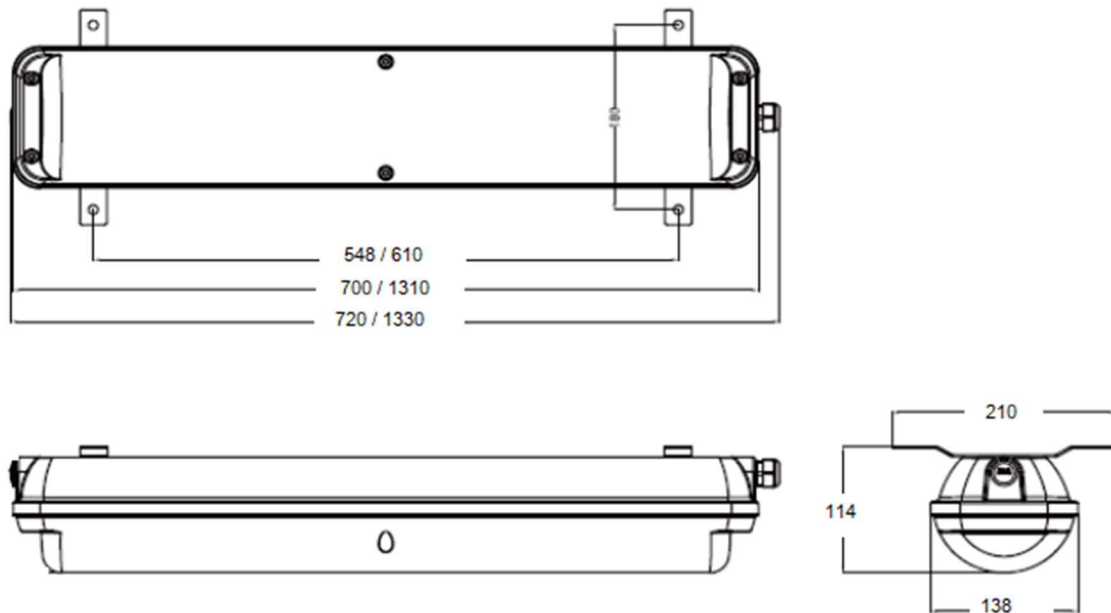

## Product Code

GLD-SW-CCT-66-OP-2F	Gladiator, 11,14,17,20w, 1320,1680,2040,2400lm, 3CCT, 720mm
GLD-SW-CCT-66-OP-4F	Gladiator, 33,40,42,50w, 3960,4800,5040,6000lm, 3CCT, 1330mm

\*\* Suffix end of code (**M3**) for emergency facility or (**BPIR**) PIR Sensor or (**BTC**) for Casambi Wireless Control

\*\*Example: GLD-SW-CCT-66-OP-2F-BTC

Gladiator, 720mm body switchable power & CCT c/w Casambi