

Skyler

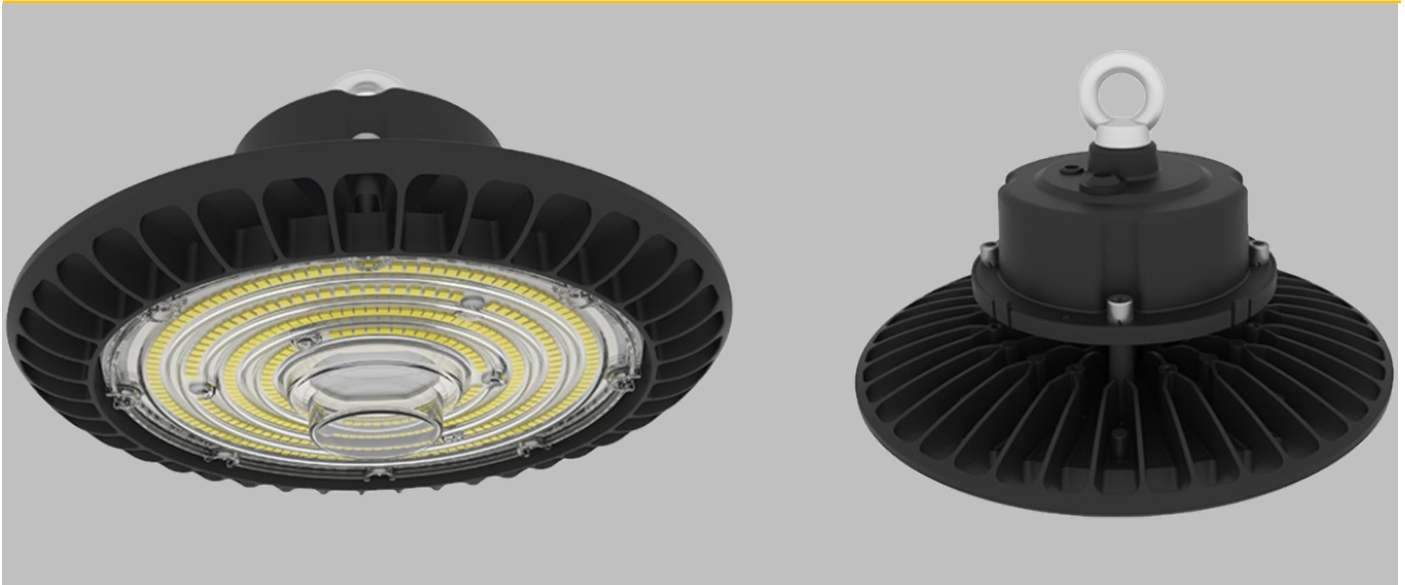

APPLICATIONS

- Factories
- Warehouses
- Cold Storage
- Industrial Areas

CONSTRUCTION

- Die-cast aluminium housing epoxy powder coated
- Stainless steel mounting hoop
- Polycarbonate optics
- IK08 impact rating

TECHNICAL DETAILS

- Various Wattages
- CRI>80
- CCT Options 4000K
- 120° Beam angle

ORDER CODE	DESCRIPTION
SK/100/4K/BK	SKYLER 100W 13000LM 4K 230mm BODY
SK/150/4K/BK	SKYLER 150W 19500LM 4K 270mm BODY
SK/200/4K/BK	SKYLER 200W 26000LM 4K 320mm BODY

DIMENSIONS

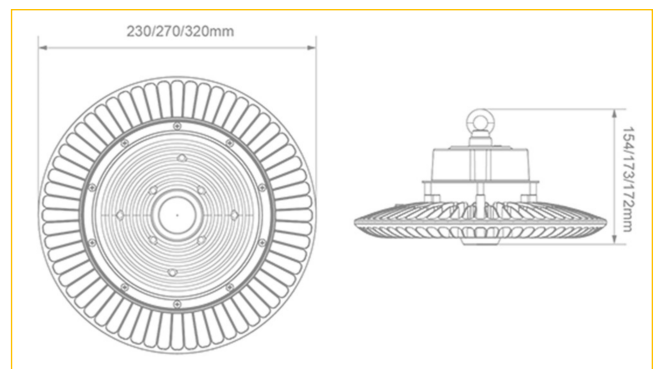

OPTIONS	DESCRIPTION
/MS	MICROWAVE SENSOR

Ordering Format: Product Code / Option

Example: SK/100/4K/BK/MS

IP66

