

XLP-3



APPLICATIONS

- Retail
- Atrium
- Display
- Reception

CONSTRUCTION

- Injection moulded body
- Body colour options
- supplied with lock bracket

TECHNICAL DETAILS

- CCT 5000K
- Suitable for - Eutrac, Global & Stucci Systems
- CRI >80
- 1 x 2w LED 209 lumens
- Lithium battery technology LiFePO4

DIMENSIONS

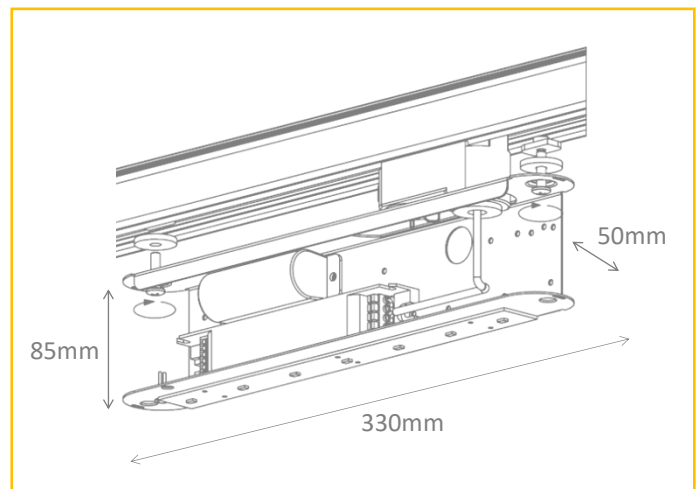

PRODUCT CODE	DESCRIPTION
XLP/NM3/WH/**	XLP NON-MAINTAINED FINISHED WHITE

OPTIONS	DESCRIPTION
/WH	WHITE BODY RAL9016
/BK	BLACK BODY RAL9005
/EU	EUTRAC ADAPTOR
/GL	GLOBAL ADAPTOR
/STC	STUCCI ADAPTOR
/DALI	3HR DALI MONITORED EMERGENCY



Ordering Format: Product Code / Option

Example: XLP/NM3/WH//DALI